

SECTION 5: COMMON BMP DESIGN ELEMENTS

5.5 Forebays

The forebay shall provide a means of drawdown for maintenance. For earthen baffles a ten foot (10') rip rap section has been successfully utilized on many wet detention ponds in Greensboro.

5.6 Earthen Impoundments, Embankments and Dams

Structural BMPs designed to impound water pose a potential hazard to downstream citizens and property. Because structural BMPs are mostly used in urbanized areas or rapidly growing areas, such as in Greensboro, potential hazards related to water impoundments and dams are increased.

The State of North Carolina Dam Safety Law of 1967 [as Amended through 1995] provides for the certification and inspection of dams in the interest of public welfare with respect to reducing the risk of failure to dams. The rules, which are provided in the North Carolina Administrative Code Title 15A, Subchapter 2K (see Appendix 3), entitled "Dam Safety," state that "no person shall begin the construction of any dam until at least 10 days after filing with the Department a statement concerning its height, impoundment capacity, purpose, location and other information required by the Department." It is important to note that the department requires notification for the construction of *any* dam even if the dam may be "exempt" from the State's regulation.

The Regulations (N.C.G.S 143-215.25A (a) (6)) exempt a dam "that is less than 15 feet in height or that has an impoundment capacity of less than 10 acre-feet, *unless the Department determines that failure of the dam could result in loss of human life or significant damage to property below the dam.*" If the failure of a dam could result in the loss of human life or significant property damage the dam is classified as a High Hazard (Class C) structure. Although many structural BMP dams that are constructed in Greensboro are smaller than the size criteria for State regulation, the fact that they are being constructed in an urban or developing area could potentially have significant impacts to human life and property. The following Table shows the quantitative guidelines used by the State Dam Safety Office for dam hazard classification.

An additional five percent (5%) of the design height of an earthen embankment dam shall be added to the top of dam elevation during fill placement to negate future settlement.

To help ensure that stormwater BMP dams have met the State Dam Safety regulations and that the dams have been designed with public health, safety, and welfare in mind the **Engineer's Statement of Pond and Dam Safety** is required for dams proposed to be constructed for stormwater BMPs that temporarily or permanently store water.

Concrete dams and spillway structures shall be designed and built in accordance with the American Concrete Institute's (ACI) latest guidelines. Particular attention shall be paid to design and analysis, water tightness, concrete quality and construction practices. Structures shall be designed and constructed to maintain water tightness by controlling and limiting cracking with proper joint design and spacing. Documentation is to be submitted with pond certification.

Dam Hazard Classification		
HAZARD CLASSIFICATION	CRITERIA	QUANTITATIVE GUIDELINES
LOW	Interruption of Road Service, Low Volume Roads	Less than 25 Vehicles per Day
	Economic Damage	Less than \$30,000
INTERMEDIATE	Damage to Highways, Interruption of Service	25 to Less than 250 Vehicles per Day
	Economic Damage	\$30,000 to Less than \$200,000
HIGH	Loss of Human Life*	Probable Loss of 1 or More Human Lives
	Economic Damage	More than \$200,000
		250 Vehicles per Day at 1000 Feet Visibility
		100 Vehicles per Day at 500 Feet Visibility
	25 Vehicles per Day at 200 Feet Visibility	
*Probable Loss of Human Life Due to Breached Roadway or Bridge on or Below the Dam		
NOTE: Cost of dam repair and loss of services should be included in economic loss estimate if the dam is a publicly owned utility, such as a municipal water supply dam.		

Engineer's Statement of Pond and Dam Safety

Engineer's Statement of Pond and Dam Safety

The stormwater pond and dam shown on this plan satisfies requirements of the North Carolina State Dam Safety Law of 1967 [As Amended Through 1995] and the Rules and Regulations as presented in the North Carolina Administrative Code Title 15A, Subchapter 2K - Dam Safety. Even in the case where the dam shown on this plan is determined by the State to be exempt from the above noted Dam Safety requirements, I, as the qualified design engineer, state that the pond and dam are designed to be safe and adequate for the protection of public health, safety, welfare, and downstream property. I understand that this statement as the design engineer shall not relieve the owner or operator of the pond and dam from the legal duties, obligations, and liabilities arising from such ownership or operation.

"In accordance with the requirements in articles GS 143-215.25A and 143-215.26 of the NC Dam Safety Law and NC Administrative Code 15A NCAC 2K .0200, the Regional Engineer in the Winston-Salem Regional Office of the NC State's Land Quality Section has been / will be contacted for the determination of whether the proposed dam is governed by or exempt from the Dam Safety Law."

When blasting is used to remove rock from the pool area, the blasted area should be over excavated to a sufficient depth below finish grade and brought back to finish grade with impervious soil material compacted in place or an alternate method can be submitted for approval. Documentation is to be submitted with pond certification.

5.6.1 Seepage Control

A filter diaphragm is a designed zone of filter material (usually well-graded, clean sand) constructed around a conduit. It has become a standard defensive design measure to prevent problems associated with seepage or internal erosion in earth fill surrounding the conduit. The use of a filter diaphragm is required around any conduit that extends through an embankment dam to the downstream slope. A drain system is required to collect the seepage at the bottom of the filter diaphragm and convey it to the downstream side of the embankment into a collection ditch or energy dissipater/stream channel. An acceptable filter diaphragm design is as given in Chapter 45, "Filter Diaphragms" National Engineering Handbook Part 628 (NEH-628), January 2007*, U.S. Department of Agriculture, Natural Resources Conservation Service (NRCS).

The design and construction of the diaphragm shall be with suitable materials conforming to the recommendations given in Chapter 26, "Gradation Design of Sand and Gravel Filters," National Engineering Handbook Part 633 (NEH-633), Soils Engineering, October 1, 1994*, published by the Natural Resources Conservation Service (NRCS). In dams constructed of fine-grained (clayey) soils commonly encountered in Greensboro, fine aggregate used in concrete (concrete sand) meeting ASTM C-33 typically meets the requirements for the filter diaphragm.

The following paragraphs and figures provide acceptable design criteria.

The alignment of the filter diaphragm is perpendicular to the longitudinal alignment of the conduit and located in the downstream section of the dam such that it is

- Downstream of the key trench (or cutoff trench)
- Upstream of a point where the embankment cover (above the upstream face of the diaphragm to the downstream face of the dam) is at least one-half the difference in elevation between the top of the diaphragm and the maximum potential pond water level (see Figure 1).

The diaphragm shall extend horizontally and vertically into the adjacent embankment fill and foundation to intercept potential seepage/leakage through cracks, poorly compacted soil zones, or other discontinuities associated with the structure or its installation. Design the diaphragms to extend the following minimum distances from the surface of the conduit and into the trench excavation for the conduit, as illustrated in Figures 1, 2, and 3.

Extend the diaphragm horizontally and vertically upward 3 times the outside diameter of the conduit (as shown in Figure 2), except that

- Vertical extension need be no higher than the crest of the auxiliary (emergency) spillway, or higher than 2 feet below the embankment surface.
- Horizontal extension need be no further than 5 feet beyond the sides and slopes of any excavation made to install the conduit.
- Horizontal extension needs to provide for keying a minimum of 2 feet into the sides or side slopes of a sloped excavation for the conduit, as shown in Figure 3.

* Downloadable from NRCS's web site at: <http://www.info.usda.gov/CED/>.

If the filter diaphragm and adjacent embankment are founded on a “firm foundation” with a “settlement ratio” (refer to Chapter 45, “Filter Diaphragms” NEH-628 referred to above) of 0.7 or greater, the filter diaphragm should extend below the pipe to a depth of 2 feet or to bedrock formation, whichever is encountered first. If the foundation is softer (settlement ratio less than 0.7), extend the diaphragm vertically downward 1.5 times the outside diameter of the conduit or down to bedrock if encountered at shallower depth. Provide a minimum diaphragm thickness (in the direction of conduit length) of 3 feet. Use a larger thickness if needed for tying into the embankment or foundation drainage systems, accommodating construction methods, or other reasons. These dimensions are shown in Figures 2 and 3.

A suitably designed drain system shall be provided in the design to receive the seepage flow intercepted by the filter diaphragm and convey it to the downstream side of the dam into a ditch or energy dissipator for the conduit or the stream channel. Two acceptable designs are shown in Figures 1 and 4. Figure 1 shows a gravel drain (surrounded by filter sand – same as in the filter diaphragm). Figure 4 shows a 4 to 6 inch slotted Schedule 40 or 80 PVC underdrain collector pipe and 4 to 6 inch solid-walled Schedule 40 or 80 PVC pipes connected near the two ends to convey the water to the downstream side of the dam.

In the case where the conduit is tied to a downstream structure, an acceptable drain system design to receive the seepage flow intercepted by the filter diaphragm is shown in Figure 5. Figure 5 shows a 4 to 6 inch slotted Schedule 40 or 80 PVC underdrain pipe within the confines of the filter diaphragm. The underdrain pipes are connected to a 4 to 6 inch solid-walled Schedule 40 or 80 PVC pipes to convey the seepage flow to the downstream structure.

If perforated PVC underdrain pipe (or slotted PVC underdrain pipe with slot width greater than 0.5 mm) is used in lieu of slotted PVC underdrain pipe with slot width 0.5 mm or less, gravel that is filter-compatible with the sand in the filter diaphragm should be used as a jacket around the perforated pipe. The gravel must also be specified to be compatible with the size of perforations or slots in the collector pipe. The criterion is that perforations or slots in the collector pipe should have a diameter or slot width that is smaller than the D_{50} size of the gravel or sand filter surrounding the pipe. For further design details refer to Chapter 45, “Filter Diaphragms” NEH-628 referenced in the first paragraph of Section 5.6.1

The granular material (typically concrete sand) in the filter diaphragm should be moderately compacted after thoroughly wetting (saturating) it, using any of the compaction methods suited to granular materials such as walk-behind vibratory rollers or manually operated plate compactors. The filter material should not be overly compacted because that can reduce the filter’s ability to “self-heal” or adjust to any movements in the underlying embankment and foundation. For guidance on compaction specifications, refer to NRCS’s publication “Drainfill, National Engineering Handbook, Part 642*,” Specification No.24.

* Downloadable from NRCS’s web site at: <http://www.info.usda.gov/CED/>.

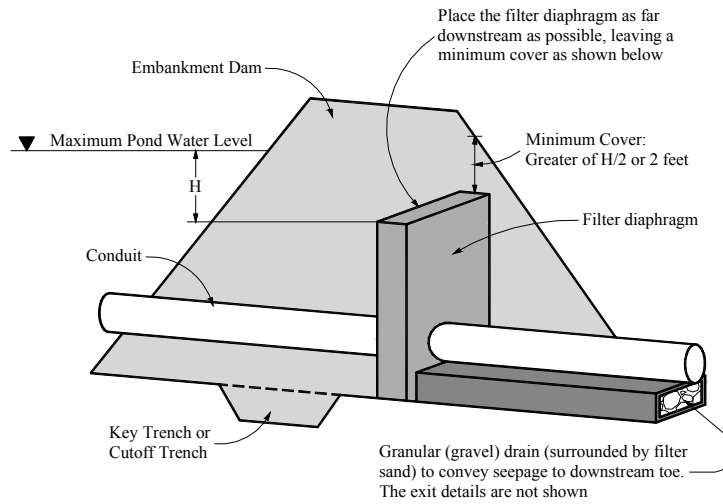

Figure 1 - Typical configuration for a filter diaphragm used in the design of an embankment dam. The figure shows the location of the filter diaphragm as far downstream as possible (downstream of key trench or cutoff trench), leaving adequate cover over it.

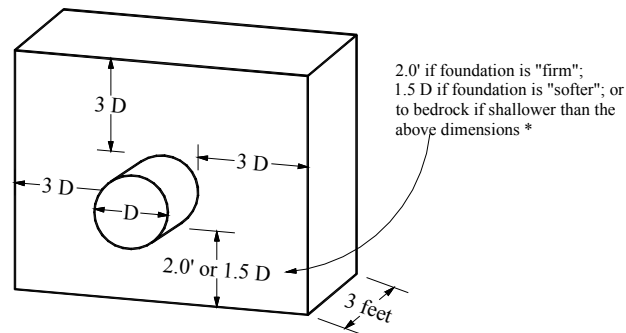

Figure 2 - Typical configuration of filter diaphragm used in the design of an embankment dam.

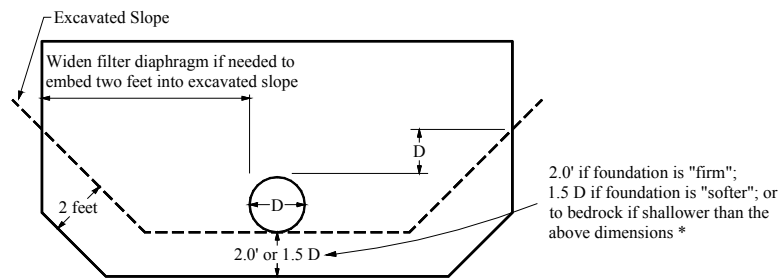
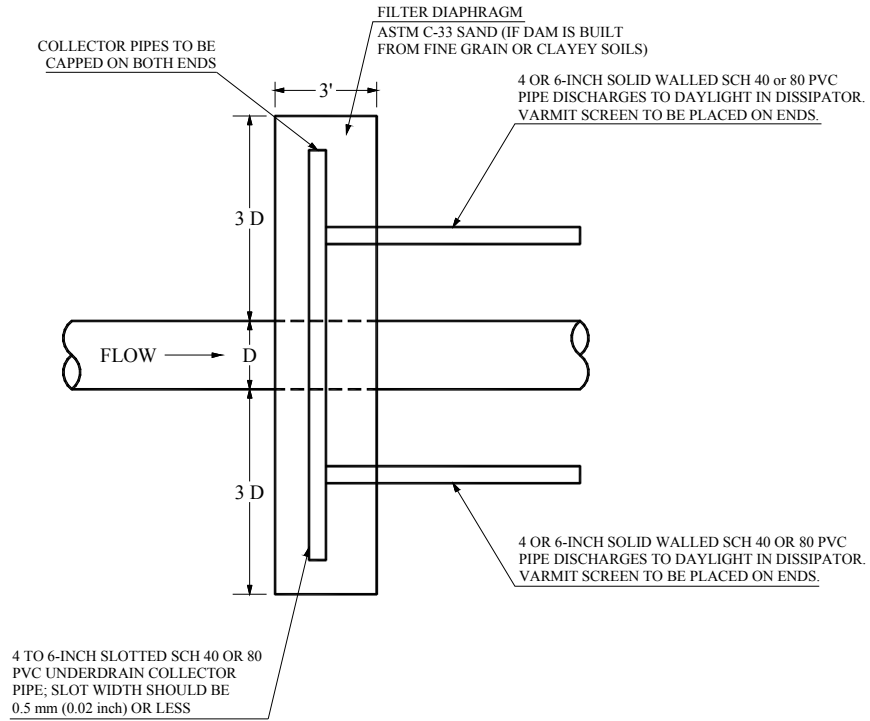
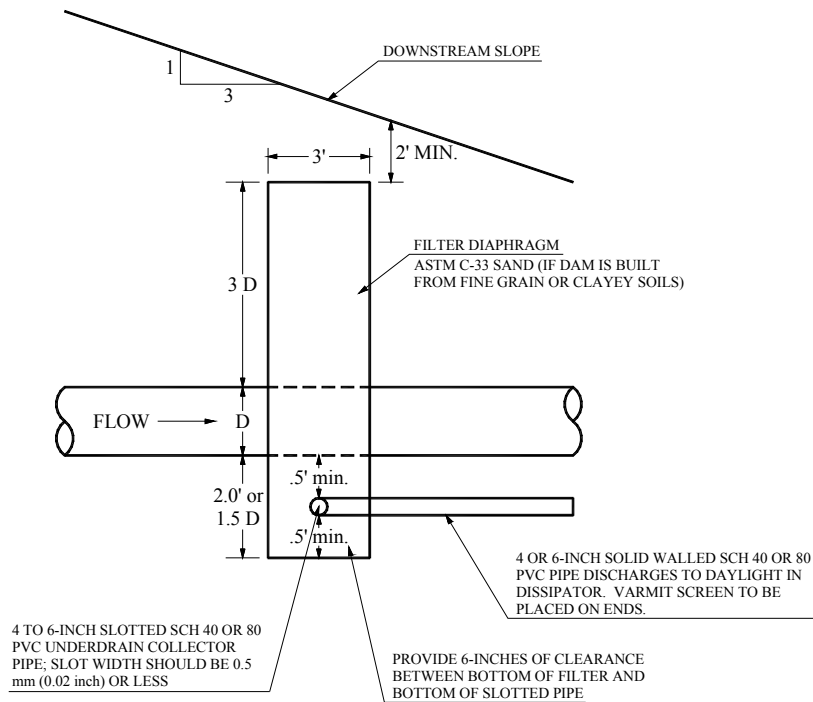

Figure 3 - Typical configuration for a filter diaphragm used in the design of an embankment dam. The filter diaphragm should extend into the foundation soils, where an excavation is made for the conduit.

* Refer to Chapter 45, "Filter Diaphragms" National Engineering Handbook Part 628 (NRCS) for details of firm and soft foundations.



PLAN VIEW



SECTION VIEW

Figure 4

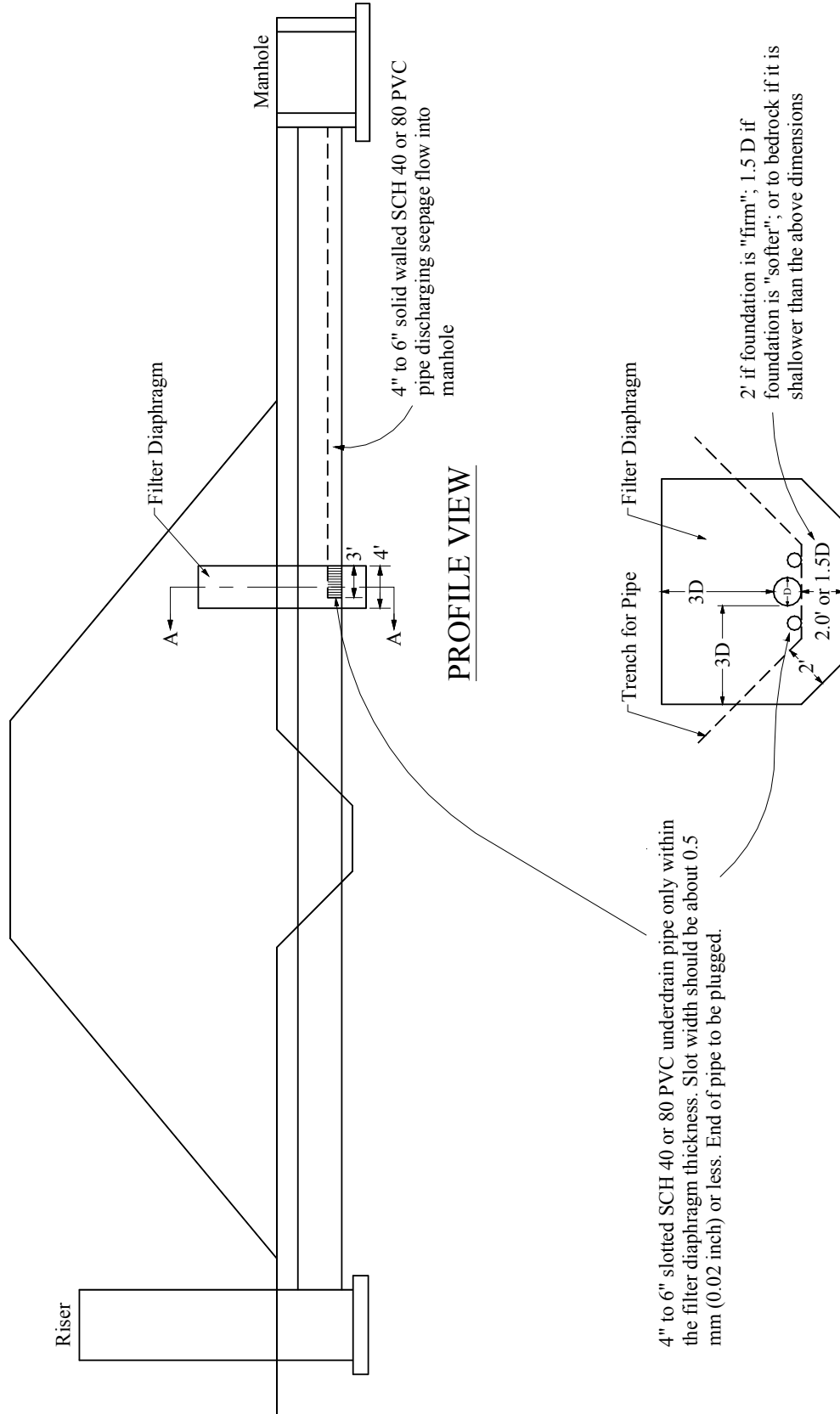

Fig. 5 Seepage Control for Outlet/Barrel Tied to Downstream Structure

5.7 Underdrain System

Other types of underdrain pipe can be utilized as long as pipe less than 10 inches in diameter has an equivalent area of openings ($0.884 \text{ in}^2/\text{ft}$) and will handle all anticipated loading conditions.

Chocking stone is basically pea gravel. Choking stone is recommended in Chapter 12 Section 12.3.5 to be #8 or #89 washed stone. Refer to Chapter 26 “Gradation Design of Sand and Gravel Filters” National Engineering Handbook Part 633 published by the Natural Resources Conservation Service for guidance in selecting the proper gravel type.

5.8 Outlets

5.8.6 Spillways

5.8.6.1 Chute Spillways

A chute spillway typically consists of an approach (entrance) channel, a control structure, a discharge channel (chute), a terminal stilling basin structure, and an outlet channel. The control structure can be a concrete wall functioning as a broad-crested weir or an ogee-shaped spillway. The alignment of the control section (crest) in plan may be a straight, semicircular, or three sides of a rectangular box. The flow is normal to the crest alignment. The control structure is typically placed near or slightly upstream of the center-line of the earth embankment in one of the abutments of the dam or in a saddle in the topography adjacent to the dam.

The requirements listed below are provided to serve as guidelines for the design of concrete chute spillways:

1. The chute spillway should preferably be placed in the cut portion in the abutment of the dam or in a saddle in the natural topography adjacent to the pond, and not in the earth fill section of the dam. The fill portion of dam has the potential to undergo deformation and settlement over time resulting in cracking and breaking-up of spillway slab.
2. The chute, downstream of the crest control section, should consist of one or two segments of concrete channel of uniform bottom slope generally conforming to grade (with no abrupt changes in grade) until it terminates in the stilling basin (energy dissipater). If there is a change in slope, the transition in the bottom should be appropriately designed (with a curve) conforming to the underside of the jet of water (typically transitioning from subcritical to supercritical flow). If the width of the chute is contracted between the control section and the downstream portion of the chute, the flare angle of the contraction should be very small to avoid the ride-up of the flow on the side walls due to “cross waves” created in supercritical flow with flares in the side walls. If the chute is fairly long, significant air entrainment in the flow might occur and the side walls of the chute should be high enough to contain the increased flow depth due to “bulking” of flow due to air entrainment. A typical incremental depth to accommodate air entrainment is 20% to 25% of the calculated depth for normal flow depth (without air entrainment).

3. A “Filter Diaphragm” should be placed around the Water Quality drain pipe. Size of the filter diaphragm should be based on the pipe diameter and depth and width of the trench for installation of pipe (or pipe can be encased in concrete as part of chute). Refer to Section 5.6.1 Seepage Control for additional details.
4. Concrete slabs and side walls of the chute should be of reinforced concrete and should have a minimum thickness of 8 inches. This will provide a reasonable assurance of a watertight lining, protection from weathering and abrasion, and resistance against ordinarily experienced forces due to expansion, contraction, frost heave, and settlement of the foundation.
5. Where the chute is founded on soils that are not free-draining (as in the Piedmont area), the concrete slabs should be underlain by a pervious gravel blanket (minimum 9 inches thick) to facilitate underdrainage (of seepage flow under the slabs). Since concrete slabs can crack, hydraulic pressure (due to seepage) can uplift slabs in the absence of a drainage blanket that reduces the pore-water pressures. Pervious blankets should have drainage control with an underdrainage pipe system leading the collected flow to a suitable downstream outlet location.
6. Concrete joints: When the chute is founded on soils (not bedrock), “cut-off walls” should be provided under the joint, constructed integral with the downstream slab, and be deep enough to anchor into the foundation soil, to prevent the creep of the slabs down the slope and consequent failure of the slabs. The upstream slab should rest on a ledge built into the downstream cutoff wall/slab unit. When the chute is founded on bedrock, the floor should be adequately anchored into the underlying rock with suitably spaced anchor bars grouted into drilled holes in the rock foundation. See typical details below.

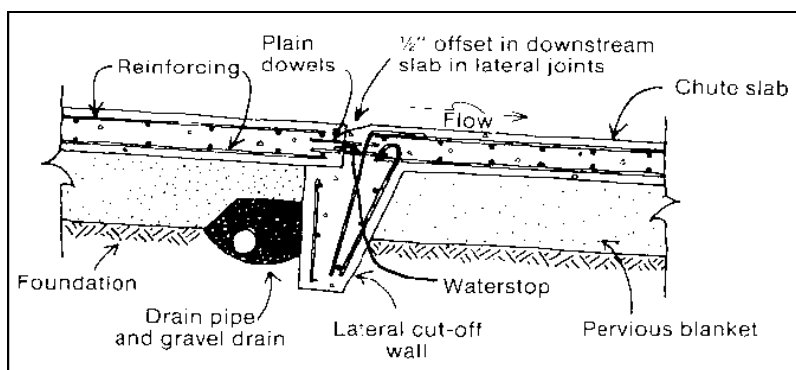

Figure 6 Typical Floor Lining on Earth (Soil) Foundations

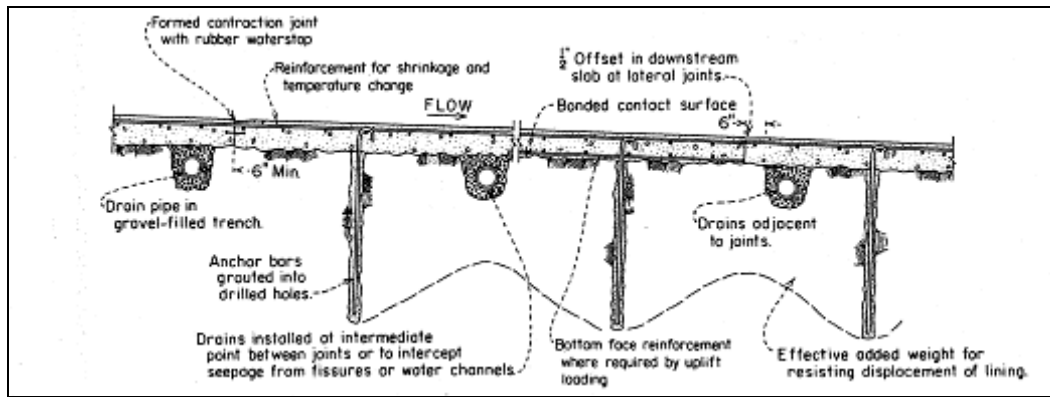

Figure 7 Typical Floor Lining on Rock Foundations

7. An appropriately designed and sized energy dissipator basin shall be located at the chute outlet. A SAF (St. Anthony Falls) stilling basin is generally considered the appropriate energy dissipator for chute spillways. Design methodologies provided in the chapter on Spillways in the book “Design of Small Dams” by the U. S. Bureau of Reclamation or in the chapter “Chute Spillways” in Section 14 of “National Engineering Handbook” by the U. S. Department of Agriculture, Soil Conservation Service (currently NRCS) are considered appropriate and acceptable. Use of riprap for spillway energy dissipation is inadequate and not recommended.
8. Ideal geometric shape for the spillway channel is rectangular. Trapezoidal channels can result in the development of secondary eddy flows and potential standing waves due to the supercritical flow conditions and make it difficult to provide adequate energy dissipation at the outlet.

The guidelines listed above conform to the standards/guidelines provided by State and Federal dam building agencies, such as NRCS (former Soil Conservation Service), Corps of Engineers and Bureau of Reclamation. As such, these guidelines represent reasonable expectations based on the documentation published by these agencies. If a proposed design deviates from these guidelines please include supporting documentation to justify the change.

The main consideration behind the implementation of these expectations is the head of water the structure is designed to hold, irrespective of the drainage area for the pond. For dams designed to have a relatively minor impoundment depth and head of water, deviation from these expectations will be considered on a case by case basis.

For additional information, refer to the “National Engineering Handbook – Section 14, Chute Spillways” published by the USDA Soil Conservation Service or “Design of Small Dams” published by the US Department of Interior Bureau of Reclamation.

5.8.6.2 Free Overfall (Straight Drop) Spillways

A “Free Overfall” (or “Straight Drop”) Spillway is one wherein the flow freely drops from the crest of a weir wall that has a vertical or nearly vertical downstream face. The weir crest may be sharp-crested or broad-crested. In some designs, the crest may be extended in the form of an

overhanging lip to direct flows away from the downstream face of the wall. The underside of the nappe of the falling jet of water is ventilated to prevent pulsations in the jet. The wall in which the weir crest is located is typically a reinforced concrete retaining wall. This type of spillway shall be limited to situations in which the differential head between the upstream (pond) water level and the tail water level (in the downstream channel) is less than 20 feet.

A properly designed stilling basin shall be provided as a part of the spillway structure to dissipate the energy of the falling water downstream of the weir wall. Three acceptable stilling basin types are:

1. Plunge Pool Basin
2. Impact Blocks Basin
3. Hydraulic jump Basin

The Impact Blocks Basin typically is a more compact (shorter length) basin compared to the Hydraulic Jump Basin and its performance is not sensitive to the required tail water depth as in the case of a Hydraulic Jump Basin. Design methodologies given in the publications such as “Design of Small Dams” by the US Bureau of reclamation and Design Manuals of the US Department of Agriculture’s Natural Resources Conservation Service (NRCS) or the US Army Corps of Engineers are acceptable. If other designs or design methods are used, calculations in support of such designs shall be submitted for City’s review.

A Plunge Pool Basin consists of an open basin, lined with concrete or riprap (placed on a geotextile for soil separation), of adequate length and of a depth (relative to the tail water level) of the plunge pool that is equal to the maximum scour depth of a free-falling jet. The length of the basin should be based on the trajectory of the falling water jet for the maximum design discharge. An empirical equation (based on experimental data) for the maximum scour depth is given in “Design of Small Dams” as follows:

$$D_s = 1.32 * (H_t^{0.225}) * (q^{0.54})$$

D_s = Maximum depth of scour below tail water level, in feet

H_t = Head differential between the head water and tail water levels, in feet

q = Discharge per foot width of the effective weir length, in cfs

The floor of the plunge pool basin would be provided at an elevation equal to or lower than the tail water elevation minus the maximum scour depth D_s . The tail water level should be determined based on the downstream channel flow characteristics (cross-section, slope, Manning’s roughness coefficient, or other downstream hydraulic controls if they exist).

Detailed procedures for determining the dimensions of the Impact Blocks Basin and Hydraulic jump Basin, including an example of design, are given in the chapter “Spillways” in the book “Design of Small Dams.” A summary of the procedures for Impact Block Basins (which is more compact/economical and less sensitive to variations in tail water level) is provided here, for ready reference. For the design procedure of Hydraulic Jump Basin (which is more complex), refer to the procedure and example given in the chapter on Spillways in the book “Design of Small Dams.”

The dimensions of the basins are given by the curves in the charts reproduced from the “Design of Small Dams” in the attached Figure, as functions of two independent variables: the “Drop Distance” (Y) and the “Unit Discharge” (q). The dimensions of the basins are given in the charts on the ordinate (in terms of Y) for a given value of the dimensionless “Drop Number” ($= q^2/gY^3$) on the abscissa. Since q^2/g is equal to $(d_c)^3$ (where d_c = critical depth of flow over the spillway), the Drop Number is also equal to $(d_c/Y)^3$.

The linear dimensions of the elements of an Impact Block Basin are as follows:

L_p is read off the attached chart (upper one)

Minimum length of basin = $L_b = L_p + 2.55 d_c$

Minimum length to upstream face of baffle block = $L_p + 0.8 d_c$

Minimum tailwater depth = $d_{tw} = 2.15 d_c$

Optimum height of baffle blocks = $0.8 d_c$

Width and spacing of baffle blocks = $0.4 d_c (+/-)$

Optimum height of end sill = $0.4 d_c$

In addition to determining the dimensions of the stilling basin from surface hydraulic considerations discussed above, the basin dimensions and thicknesses of the floor and walls of the basin structure shall also be designed based on considerations of the uplift and lateral pressures associated with the subsurface seepage flow beneath and adjacent to the spillway and stilling basin structure, as it affects the global stability and structural strength of the elements of the structure. The length of the spillway and stilling basin structure shall also be checked for insuring against high “exit gradient” of seepage flow immediately downstream of the structure to prevent “piping” problem of soil particles from the foundation or backfill against the walls being carried away with seepage flow.

SPILLWAYS

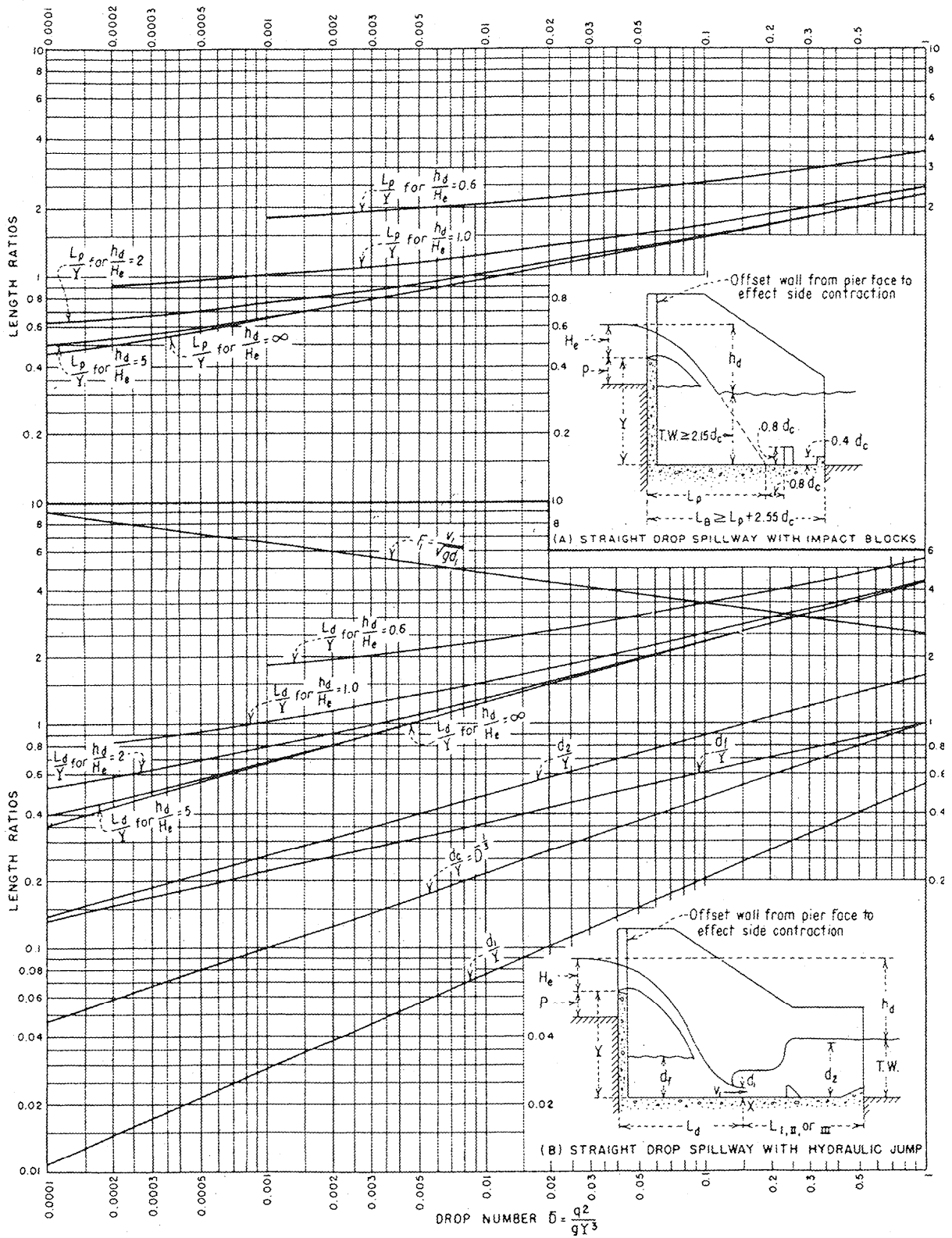

Figure 9-53.—Hydraulic characteristics of straight drop spillways with hydraulic jump or with impact blocks. 288-D-2437.

5.8.8 Trash Racks

An underflow type trash guard is preferred over conical type trash guards. Experience has shown underflow type trash guards to be highly effective in preventing clogging and superior in preventing litter and debris from being transported downstream.

SECTION 6: BMP Facility Planting and Soil

6.4 Landscape Plans

The design of the following structural BMP's must include a landscape plan prepared in accordance with Section 6.4.1 and plantings placed in accordance with Section 6.4.2 of the State BMP Manual:

- Stormwater Wetlands
- Wet Detention Basin
- Bioretention Cell

A one year (1 yr) warranty period is customary and acceptable. A note on the plan must be added making reference to the one year warranty.

6.4.2 - Trees or shrubs shall not be planted on portions of water impounding embankments.

6.5.1 Soils Analysis

A soils analysis / report as outlined in Section 6.5.1 of the State BMP Manual will be prepared and submitted to the City of Greensboro Stormwater Division for the structural BMP's listed above. For wet detention basins and Stormwater wetlands the soils analysis must include an analysis of the viability of the soils to retain a permanent pool.

6.5.3 Soil Specifications

Soils used within any BMP proposed within the City of Greensboro must adhere to the specifications listed in Section 6.5.3 of the State BMP Manual.

SECTION 7: BMP INSPECTION AND MAINTENANCE

7.2. Legal and Financial Issues

7.2.2 Inspection and Maintenance Agreements

The City's water-supply watershed (Ch. 30) ordinance and the 1999 stormwater management (Ch. 27) ordinance require that BMPs which are constructed to meet these requirements must be maintained by the property owner or owners' association. The BMPs must be maintained to continue to function to meet the regulations it was designed for. The City has the authority to inspect these BMPs periodically and require the BMP owner to perform maintenance activities, when necessary.